

Ultimate Engine Analyzer

(US-8A)

Operating and Installation Instructions

OI072491 and II072091

7/20/89

Rev. B: 2/1/93 **

You must read this manual before installing or operating the instrument. This manual contains warranty and other information that may affect your decision to install this product and/or the safety of your aircraft.

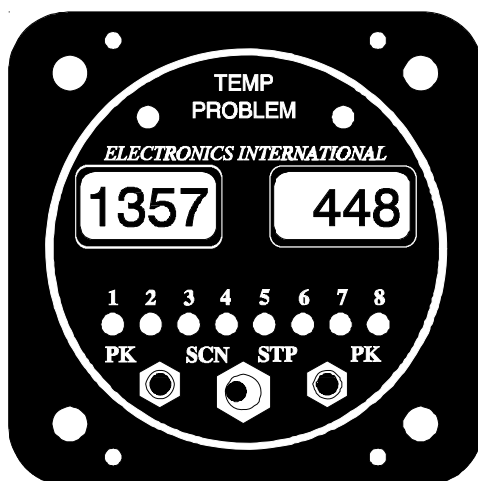

S/N: _____



Electronics International Inc. ®

63296 Powell Butte Hwy • Bend, OR 97701 • (541) 318-6060 • Buy-EI.com 

Important Notice

******* MUST READ *******

If you think it is not important to read this manual, you're wrong! This manual contains important installation information that may affect the safety of your aircraft, delay your installation or affect the operation of your instrument. You Must read this manual prior to installing your instrument. Any deviation from these installation instructions is the sole responsibility of the installer/pilot and may render the STC invalid.

Read the Warranty / Agreement. There is information in the Warranty / Agreement that may alter your decision to install this product. **If you do not accept the terms of the Warranty / Agreement, do not install this product.** This product may be returned for a refund. Contact Electronics International inc. for details.

Check that the instrument make and model marked on the side of the instrument and on the invoice are correct before starting the installation.

It is possible for any instrument to fail thereby displaying inaccurate high, low or jumpy readings. Therefore, you must be able to recognize an instrument failure and you must be proficient in operating your aircraft safely in spite of an instrument failure. If you do not have this knowledge, contact the FAA or a local flight instructor for training.

The ability for this product to detect a problem is directly related to the pilots ability to program proper limits and the pilots interpretation and observation skills.

The pilot **must** understand the operation of this product before flying the aircraft. Do not allow anyone to operate the aircraft that does not know the operation of this product. **Keep the Operating Manual in the aircraft at all times.**

P-110 Standard EGT Probe

Important Installation Information

All steps must be read before installing a probe.

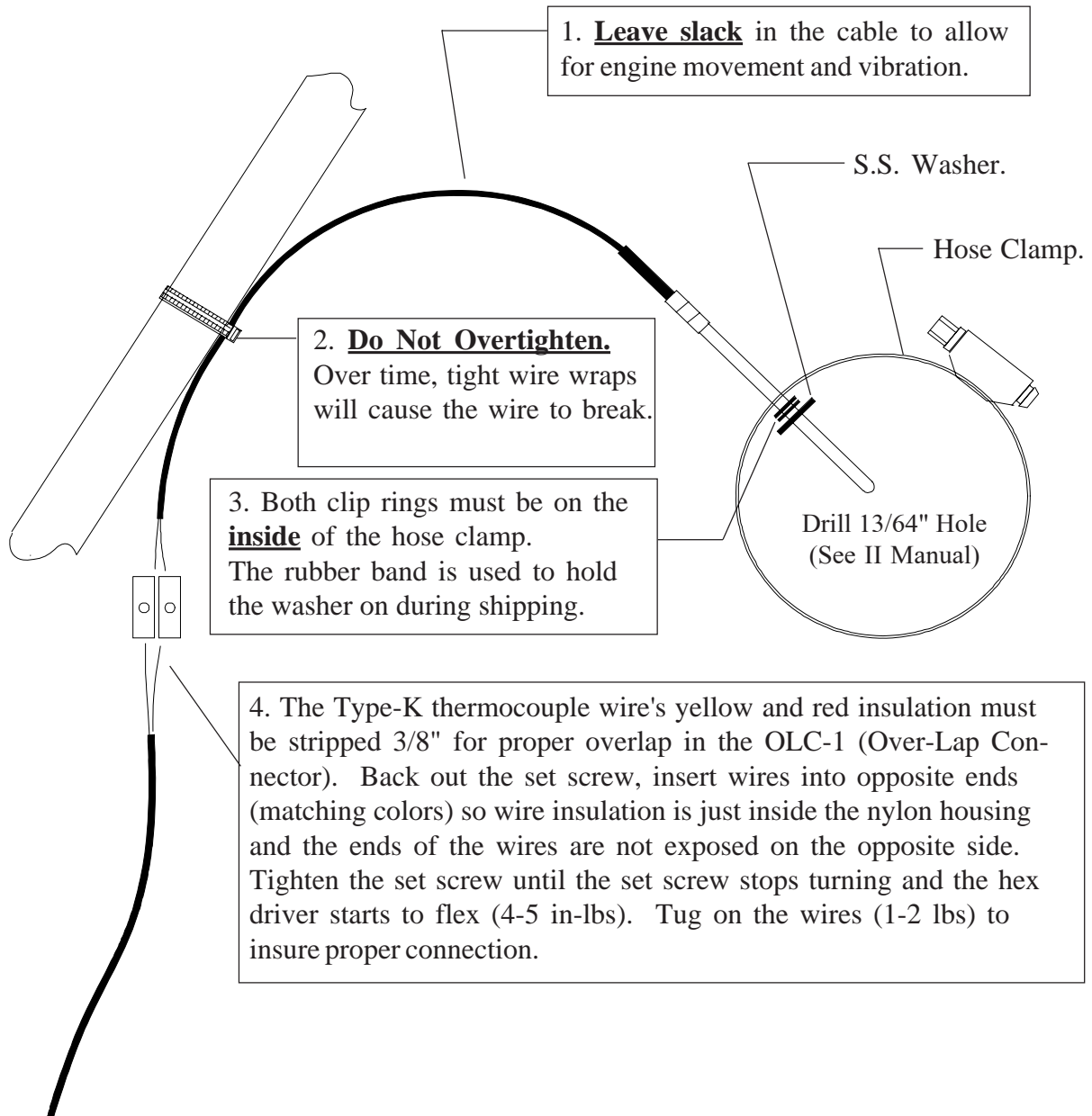

P-110 Fast Response EGT Probe

Important Installation Information

1218122

All steps must be read before installing a probe.

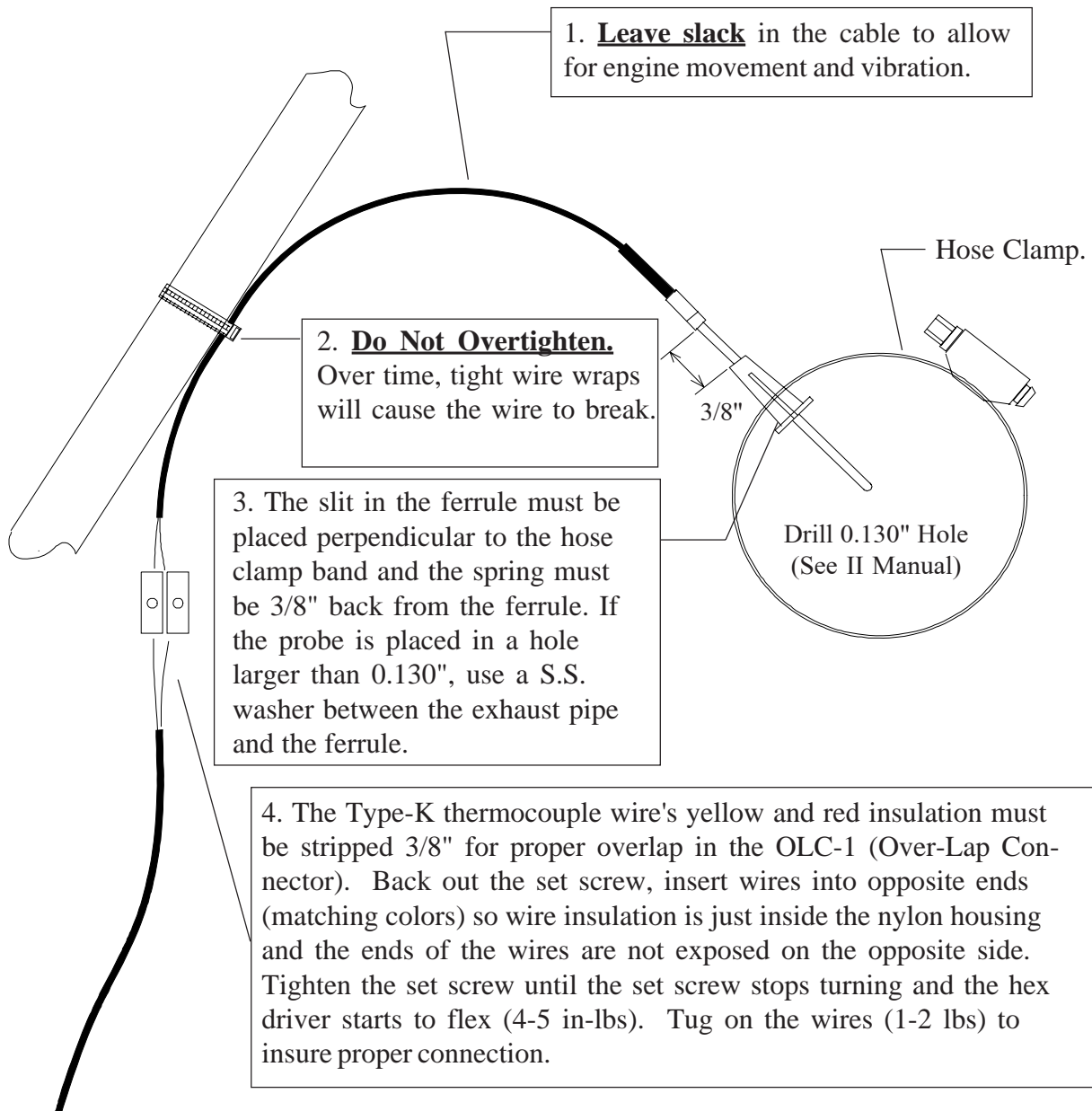

Contents

Warranty	2
Operating Information	3
Introduction	3
Features	3
Programming	6
Selecting The Proper Limits	10
Operating The Ultimate Analyzer in Your Aircraft	15
Installation Instructions	18
1. Important Information and Initial Check Out	18
2. CHT Probe Installation	19
3. EGT Probe Installation	19
4. TIT Probe Installation	20
5. Oil Temperature Probe Installation	20
6. Carb. Temp. Probe Installation	20
7. OAT Probe Installation	21
8. Add any Additional Cables and Mark each Cable	21
9. Route The Circular Connector	22
10. Route Each Extension Cable	22
11. Hook Up Connecting Wires	22
12. Instrument Installation	23
13. System Ground Test	24
Wiring Diagrams	25
Troubleshooting Suggestions	28
Specifications and Operating Features	30
Appendix A - Adding a Channel to the US-8A	32
Appendix B - US-8A Circular Connectors	33
STC Information	34

Warranty / Agreement

Electronics International Inc. warrants this instrument and system components to be free from defects in materials and workmanship for a period of one year from the user invoice date. Electronics International Inc. will repair or replace any item under the terms of this Warranty provided the item is returned to the factory prepaid.

1. This Warranty shall not apply to any product that has been repaired or altered by any person other than Electronics International Inc., or that has been subjected to misuse, accident, incorrect wiring, negligence, improper or unprofessional assembly or improper installation by any person. **This warranty does not cover any reimbursement for any person's time for installation, removal, assembly or repair.** Electronics International retains the right to determine the reason or cause for warranty repair.
2. This warranty does not extend to any machine, vehicle, boat, aircraft or any other device to which the Electronics International Inc. product may be connected, attached, interconnected or used in conjunction with in any way.
3. The obligation assumed by Electronics International Inc. under this warranty is limited to repair, replacement or refund of the product, at the sole discretion of Electronics International Inc.
4. Electronics International Inc. is not liable for expenses incurred by the customer or installer due to factory updates, modifications, improvements, upgrades, changes, or any other alterations to the product that may affect the form, fit, function or operation of the product.
5. Personal injury or property damage do to misinterpretation or lack of understanding this product is solely the pilots responsibility. The pilot **must** understand the operation of this product before flying the aircraft. Do not allow anyone to operate the aircraft that does not know the operation of this product. Keep the Operating Manual in the aircraft at all times.
6. E. I. Inc. is not responsible for shipping charges or damages incurred under this Warranty.
7. No representative is authorized to assume any other liability for Electronics International Inc. in connection with the sale of Electronics International Inc. products.
8. **If you do not agree to and accept the terms of this warranty, you may return the product for a refund.**

This Warranty is made only to the original user. **THIS WARRANTY IS IN LIEU OF ALL OTHER WARRANTIES OR OBLIGATIONS: EXPRESS OR IMPLIED. MANUFACTURER EXPRESSLY DISCLAIMS ALL IMPLIED WARRANTIES OF MERCHANTABILITY OR FITNESS FOR A PARTICULAR PURPOSE. PURCHASER AGREES THAT IN NO EVENT SHALL MANUFACTURER BE LIABLE FOR SPECIAL, INCIDENTAL OR CONSEQUENTIAL DAMAGES, INCLUDING LOST PROFITS OR LOSS OF USE OR OTHER ECONOMIC LOSS. EXCEPT AS EXPRESSLY PROVIDED HEREIN, MANUFACTURER DISCLAIMS ALL OTHER LIABILITY TO PURCHASER OR ANY OTHER PERSON IN CONNECTION WITH THE USE OR PERFORMANCE OF MANUFACTURER'S PRODUCTS, INCLUDING SPECIFICALLY LIABILITY IN TORT.**

US-8A

OPERATING INFORMATION

S1004911

OI 072491

Rev. A 10/04/91

Introduction

The Ultimate Analyzer is one of the most sophisticated diagnostic tools you can buy for your aircraft. You can learn the basic operation of this unit in the first few minutes of hands-on operation. Although the Ultimate Analyzer is simple to operate, its capabilities are numerous. This manual covers the operation of the Ultimate Analyzer in the following four sections:

1. **Features** - Describes the operating features of the Ultimate Analyzer.
2. **Programming** - Describes how to program the Ultimate Analyzer.
3. **Selecting the Proper Limits** - Describes how to select the limits that should be programmed into the Ultimate Analyzer.
4. **Operating the Ultimate Analyzer in Your Aircraft** - Describes how to operate the Ultimate Analyzer for the different phases of a flight (taxi, run-up, takeoff, climb, cruise and descent).

Features

Temperature Problem

Warning Lights

Left Display Window

Left Peak

Locate Switch

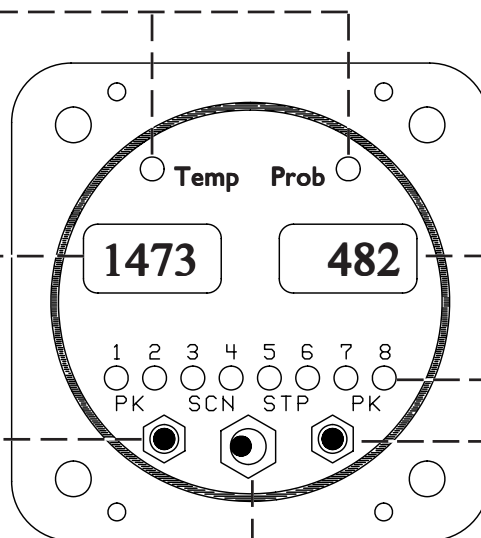

Right Display Window

*Channel
Indicators (8ea.)*

*Right Peak
Locate Switch*

Mode Selector Switch:

Left Position = Scan Mode

Center Position = Manual Mode

Right Position = Step

1. Multi-Function Capability

The Ultimate Analyzer has up to 16-channel capability, 8 for each of the displays. For a 6-cylinder single engine aircraft, the first 6 channels on the left display should be used for EGT and the first 6 channels on the right display should be used for CHT. For a twin-engine aircraft the first 6 channels should be left EGT and right EGT. These channels are designated as analyzer channels. The Peak Locate, Hottest Cylinder Indicator and Differential Warning features are only functional on the analyzer channels. The number of analyzer channels is independently programmable from 1 to 8 for each display. The High-Temp and Low-Temp features are functional on all channels and may be used to measure any temperature (TIT, Oil, EGT, CHT, OAT, Carb, Induction Air, Cabin Air, Cowling Air, Intercooler, Water, etc.).

2. Mode Select Switch

A) Manual Mode - With the Mode Select Switch in the center position, the Ultimate Analyzer will display the temperatures on the channel designated by the green Channel Indicators. No other channels are being monitored at this time. In the Manual Mode the Shock-Cooling and High-Temp warning features are enabled for only the channel displayed. The Low-Temp and Differential warning features are disabled so you may operate the aircraft at idle and taxi without getting warning lights.

B) Step Position - Each time the Mode Select Switch is pressed to the right, the Ultimate Analyzer will advance to the next channel. When this switch is released, it will return to the center position (Manual Mode). The Ultimate Analyzer can be programmed from the front panel to step through 2 to 8 channels.

C) Scan Mode - In the Scan Mode, the Ultimate Analyzer will scan through the channels, automatically analyzing your engine. When the unit is first placed into the Scan Mode, it will switch to Channel One to start its scan. This is done to establish a reference for the automatic engine analysis features.

In the Scan Mode the High-Limits, Low-Limits, and Differential warning features are enabled. The Shock-Cooling feature is disabled (Shock-Cooling is only a problem during descents).

The Ultimate Analyzer may be placed in the Scan Mode during run up, takeoff, climb or cruise, as long as the engine temperatures are increasing or stable and above the programmed lower limits. This unique operating characteristic allows the Ultimate Analyzer to stand watch over your engine during most phases of a flight. But if the engine temperatures are decreasing (which would occur on a descent) or low (which would occur at idle, the Ultimate Analyzer should be placed into the Manual Mode of operation to eliminate any false Low or Differential Condition problems it may find and to enable the automatic Shock-Cooling detection feature.

3. Peak Locate Switch

There are two Peak Locate Switches, one for the left display and one for the right. The Peak Locate feature may be used in the Manual or Scan Mode of operation. Its purpose is to eliminate all of the mental calcula-

tions and time to find the hottest cylinder. This can be a real asset in leaning or locating a possible problem. When used for EGT leaning, it should be noted that the leanest cylinder is not always the hottest; but it is the cylinder you want to start your leaning process on. Precision leaning will then be done to 1°F and the Leanest Cylinder will be verified. Leaning will be covered later in this manual.

A) Manual Mode - To find the hottest analyzer cylinder in the Manual Mode, press the “Peak” button. The Ultimate Analyzer will automatically switch to Channel One and start a fast scan (one second per channel). It will only scan through the analyzer channels and jump to the hottest channel when done.

B) Scan Mode - You may also use the Peak Locate feature in the Scan Mode. The Ultimate Analyzer will operate the same as in the Manual Mode. After it has found the hottest analyzer channel it will continue scanning at the programmed scan rate.

4. Hottest Cylinder Indicator

In the Scan Mode only, the Ultimate Analyzer will light a bar high in the left hand corner of the display any time it is displaying the hottest analyzer cylinder. This feature allows you to determine if the leanest cylinder has changed. If this happens, you may need to readjust your mixture.

5. “Temp Prob” Warning Lights (Automatic Engine Analysis)

A) High-Temp Problem (Scan and Manual Modes) - If the temperature being displayed exceeds the programmed limit, the “Temp Prob” warning light over the appropriate display will come on. Also, there will be a bar high in the left hand corner of the display. If you are in the scan mode, the scan will stop on the problem channel.

B) Low-Temp Problem (Scan Mode only) - If the temperature being displayed is less than the programmed Low Limit, the “Temp Prob” warning light over the appropriate display will come on. Also, there will be a bar low in the left hand corner of the display and the scan will stop on the problem channel.

C) Differential Temp Problem (Scan Mode only) - Any time the temperature difference between the hottest and coldest channel exceeds the programmed differential limit the “Temp Prob” warning light over the appropriate display will come on. Also, the high and low bar in the left hand corner of the display will alternately blink and the Ultimate Analyzer will stop on the coldest cylinder. In this case, the problem may be the coldest cylinder or it may be the hottest cylinder. By comparing temperatures with adjacent cylinders the problem cylinder will become apparent. To quickly find the hottest cylinder, press the “PK” button on the front panel.

D) Shock-Cooling Temp Problem (Manual Mode only) - Any time you are on a channel on which the High Limit has been programmed between 300°F and 600°F (this indicates a CHT channel) and the temperature being monitored is between 300° and 600°F (this is the critical range of cylinder head temperatures) and the temperature is decreasing faster than the programmed limit, the appropriate “Temp Prob” warning light will blink.

NOTE: The Ultimate Analyzer will stop on the first channel on which it finds a problem and light the appropriate “Temp Prob” warning light. If the problem corrects itself, the “Temp Prob” warning light will go out and the Ultimate Analyzer will continue its scan.

6. Back Light and Green Channel Indicator Intensity

The Ultimate Analyzer comes with 12 and 24 volt digital display back light control lines. The digital display should be backlit all the time. This will allow it to be easily viewed in dim light. The digital display is best viewed in high ambient light or direct sunlight.

Also provided is a Green Channel Indicator Intensity Control Line. If this line is connected to your Panel Light Rheostat, the Green Channel Indicators’ intensity can be controlled for night operation. As the Panel Light Rheostat is turned up the Green Channel Indicators will dim. If you find the Green Channel Indicators to be too bright during daytime operation, turn the Panel Light Rheostat up slightly to control the intensity of the Green Channel Indicators to suit your requirements.

Programming

Although programming may be new to some of you, programming the Ultimate Analyzer is simple. After a few tries, you should have the hang of it. No matter which buttons you push or limits you set you cannot hurt the Ultimate Analyzer and any limit can be reset.

Your objective is to set the limits on the Ultimate Analyzer just outside the normal operating temperatures for each measured parameter (see “Selecting the Proper Limits” section of this manual). The 36 programmable limits allow you to characterize the Ultimate Analyzer to your engine. That means trend analysis and problem detection is done automatically every 16 seconds and you are alerted as soon as a problem starts to occur (i.e., if an engine temperature starts to drift high or low from its normal operating temperature range it will be detected by a High, Low or Differential limit). This is a far better method of trend analysis than pouring over pages of data every six months.

The golden rule for setting the limits on the Ultimate Analyzer is “No Red Light During Take-Off, Climb or Cruise.” The following sections will describe how to program the Ultimate Analyzer.

1. Manual Programming Mode

There are two programming modes: Manual and Scan. In the Manual Mode you can program the High Limits, Low Limits, Differential Limits and Shock-Cooling Limits for both the left and right displays. Before setting your limits it may be helpful to read the “Selecting the Proper Limits” section of this manual to get an idea where the limit should be set.

To enter the Manual Programming Mode, select the channel you would like to program using the “Stp” position on the Mode Selector Switch. Then with the Mode Selector Switch in the center position, push both “Pk” buttons at the same time. This will put you in the Manual Programming Mode displaying the High Limit for the channel you selected.

A) Programming a High Limit - There will be a bar in the upper far left corner of the left and right Display Windows. This high bar indicates you are programming the High Limit. The digit blinking is the only digit you can program at this time.

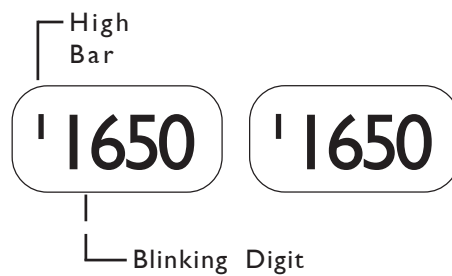

1) Select a Digit - The left and right Peak Locate Switches can be used to select the desired digit you would like to program. Push the right button to select the next digit to the right of the one currently blinking. Push the left button to select the next digit to the left of the one currently blinking. In this same manner you can select a digit in the left or right window.

2) Advance a Digits Count - Use the Step Position on the Mode Selector Switch to advance the blinking digit to the desired limit you would like. When the digit is advanced past 9 (19 for the far left digit) it will reset to 0. Programming all digits to “0000” will disable the High Limit.

3) Changing Functions - If you are done programming the High Limits for this channel and would like to program the Low limits, place the Mode Selector Switch in the Scan position. In this manner the Mode Selector Switch will call up the different functions in the following sequence:

High Limit (set on each channel).

Low Limit (set on each channel).

Differential Limit (set once, shows up on all channels).

Shock-Cooling Limit (set once, shows up on all channels).

4) Leaving the Programming Mode - You may leave the programming mode at any time by pushing both Peak Buttons at the same time. When this is done, the programmed information is stored in an EEPROM memory for life, unless you program in new limits. The Ultimate Analyzer does not use any internal batteries and the information will not be lost if the unit is disconnected from power or removed from the aircraft.

B) Programming the Low Limit - If you have selected the Low Limit to be programmed there will be a bar low in the far left hand corner of the left and right Display Windows. This bar indicates you are programming the Low Limit. The Low Limit may be programmed as shown in steps A-1 and A-2.

To move from programming the Low Limit to programming the Differential Limit, place the Mode Selector Switch in the “Scn” position once again. If the Differential limits and Shock-Cooling limits have already been set, you may want to leave the programming mode at this time (see step A-4). Differential and Shock-Cooling Limits will show up on each channel even though they only need to be programmed one time.

C) Programming the Differential Limit - There will be NO bars in the far left hand corner of the left and right Display Windows. This indicates you are programming the Differential Limit. The Differential Limit sets the maximum allowed difference between the hottest cylinder and the coolest cylinder for the analyzer channels only. Analyzer channels would be EGT’s or CHT’s and always start with channel one. There is only one Differential Limit for each Display Window. This limit can be set on any channel but only needs to be set once. The Differential Limit may be programmed as shown in steps A-1 and A-2.

To program the Shock-Cooling Limit, place the Mode Selector Switch in the Scan position once again.

D) Programming the Shock-Cooling Limit - The Shock-Cooling limit will be preceded by an “Sc” in the left and right Display Windows. The limit is displayed in seconds per one degree change. The Shock-Cooling Limit may be programmed as shown in steps A-1 and A-2.

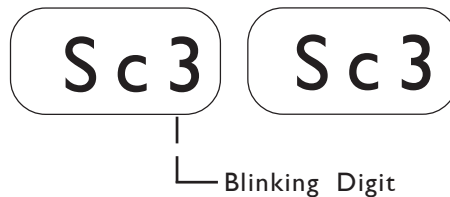

To program the High Limit, place the Mode Selector Switch in the Scan position once again and go to step A. Every time you go to the Scan position you will be selecting the programmable limits as follows:

- High Limit (set on each channel).
- Low Limit (set on each channel).
- Differential Limit (set once, shows up on all channels).
- Shock-Cooling Limit (set once, shows up on all channels).

To leave the programming mode, see step A-4.

2. Scan Programming Mode

There are two programming modes: Manual and Scan. In the Scan Mode you can program the following functions in the sequence listed below:

- Scan Rate.
- Last Channel to be scanned.
- Analyzer Channels (6 EGT's, 6 CHT's, etc).

To enter the Scan Programming Mode, place the Mode Selector Switch in the Scan position and push both Peak buttons at the same time. It does not matter which channel is being displayed when you do this.

A) Programming the Scan Rate - In the left display will be the letters "Scn", indicating you are programming the Scan Rate. In the right display will be the Scan Rate displayed in seconds. This number indicates the time the Ultimate Analyzer will display a channel before stepping to the next channel. The Scan Rate may be programmed from 2 to 9 seconds per channel by using the "Stp" Position on the Mode Selector Switch.



To program the Last Channel to be scanned, place the Mode Selector Switch in the "Scn" Position once again.

B) Programming the Last Channel - In the left display will be the letters "Ch", indicating you are programming the Last Channel to be used. In the right display will be the last channel the Ultimate Analyzer will display before resetting to channel one. The Last Channel may be set by using the Step Position on the Mode Selector Switch.



To program the Analyzer Channels, place the Mode Selector Switch in the Scan Position once again.

C) Programming the Analyzer Channels - In the left and right display will be "1-?", indicating you are programming the Analyzer Channels. The "?" will be a number between 1 and 8 and is programmable. If you have a 6-cylinder engine and have the left display channels 1 through 6 connected to EGT's and the right display channels 1 through 6 connected to CHT's, you would program the left and right display for "1-6" (a

4-cylinder engine would be programmed for “1-4”). This would set up the first six channels to be analyzed against the Differential Limit and these channels are the only ones looked at when the Peak Button is pressed. Channels 7 and 8 may be used for any other temperature measurement without interfering with the Differential or Peak Locate features.

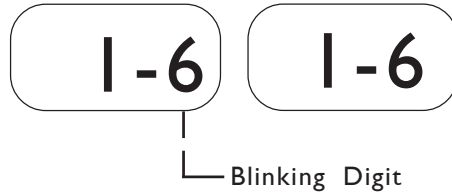

To program the Analyzer Channels use the Step position on the Mode Selector Switch to advance the count. The Peak Buttons may be used to select the left or right digit. To leave the programming mode, press both Peak Buttons at the same time.

Selecting the Proper Limits

Your objective is to set the limits on the Ultimate Analyzer just outside the normal operating temperatures for each measured parameter. The 36 programmable limits allow you to personalize the Ultimate Analyzer to your engine. That means trend analysis and problem detection is done automatically every 16 seconds and you are alerted as soon as a problem starts to occur (i.e., if an engine temperature starts to drift high or low from its normal operating temperature range it will be detected by a High, Low or Differential limit).

The golden rule for setting the limits on the Ultimate Analyzer is “No Red Light During Take-Off, Climb or Cruise.” Some General Limits that provide a good starting point for most aircraft are given below:

- EGT High Limits ----- 1550°F
- EGT Lower Limits ----- 1100°F

- TIT High Limit ----- 1650°F
- TIT Lower Limit ----- 1100°F

- CHT High Limits ----- 430°F
- CHT Lower Limits ----- 150°F

- Oil High Limit ----- 220°F
- Oil Lower Limit ----- 50°F

- OAT High and Low Limit --- 000 (Limits disabled)

- Carb Temp High Limit ----- 150°F
- Carb Temp Lower Limit ----- 37°F

These limits are only a starting point. More specific information on how to select the proper temperature limits for your engine is provided below.

1. EGTs

The Exhaust Gas Temperatures are directly related to your engine's ability to produce power. If any cylinder has a problem producing power (fouled plug, burned or stuck valve, broken ring, intake leak, plugged injector, timing problem, bad mag, etc.) the EGT's for that cylinder will be abnormally high or low depending on the problem. Each cylinder on your engine operates differently and has a normal operating temperature of its own. The Ultimate Analyzer is capable of being programmed to match each cylinder on your engine. When selecting the following limits, it is assumed your engine currently does not have a problem and is operating properly.

A) Selecting the High EGT Limits: At 75% power, lean your engine to peak EGT. Record the EGT readings for each cylinder. Program the High Limit for each cylinder 40°F above the recorded readings for that cylinder. This is only a recommended limit. As you get to know your engine's normal operating temperatures you may want to adjust these limits accordingly.

B) Selecting the Lower EGT Limits: Set your aircraft up in a normal low cruise power condition. Adjust the mixture full rich and wait for the EGT's to stabilize. Once the EGT's have stabilized, record the EGT readings for each cylinder. Program the Lower Limit for each cylinder 40°F below the recorded readings for that cylinder. This is only a recommended limit. As you get to know your engine's normal operating temperatures you may want to adjust these limits accordingly.

C) Selecting the EGT Differential Limit: Your engine's EGT's will vary for different power, altitude and mixture settings. To further enhance the Ultimate Analyzer's ability to detect a problem, set your aircraft up in a normal cruise power condition. Lean your engine and wait for the EGT temperatures to stabilize. Record the EGT's for each cylinder. Set the Differential Limit for 40°F higher than the difference between the hottest and coldest EGT readings (i.e., Hottest EGT - Coldest EGT + 40°F = Setting). This is only a recommended limit. As you get to know your engine's normal operating temperatures you may want to adjust this limit accordingly.

2. TIT

Running your engine with turbine inlet temperatures (TIT) above 1650°F can cause hairline thermal stress cracks in the turbine housing. Also, it can cause detonation and preignition, which will lead to burned valves, bent valve stems, broken rings and cracked exhaust systems. Controlling your TIT temperatures is essential for turbo-charged aircraft.

The Ultimate Analyzer will continuously monitor your TIT in the scan mode. If the TIT exceeds 1650°F, the Ultimate Analyzer will stop and light a bright red warning light over the display, immediately alerting

the pilot of an over-temperature condition. This is an important feature for turbo-charged aircraft since turbine inlet temperatures can easily creep above limit after a change in power or mixture settings.

Another advantage of the Ultimate Analyzer over conventional gauges is its extreme accuracy and linearity. This assures you of accurate TIT readings.

Turbine housing life is also affected by sudden changes in temperature. Thermal shock can occur during abrupt changes in the mixture or power settings. Make gentle changes in the mixture and power settings when transitioning from a higher TIT to a lower temperature. The Ultimate Analyzer's 1°F resolution will help in assuring that the proper transitioning of the TIT is taking place.

A) Selecting the High TIT Limit: At 75% power, lean your engine to peak TIT. Allow the TIT temperature to stabilize. Set your High TIT Limit for 40°F above this temperature. Do not exceed the maximum limit allowed for your aircraft. For most aircraft this limit will be 1650°F.

B) Selecting the Lower TIT Limit: Set your aircraft up in a normal low cruise power condition. Adjust the mixture full rich and wait for the TIT to stabilize. Program the Lower TIT Limit 40°F below this temperature.

3. CHTs

The Ultimate Analyzer helps you protect your engine against the threat of excessive heat. Most general aviation aircraft take the CHT off the hottest cylinder determined by extensive flight tests. Minimum in-flight CHT should be 150°F, and maximum in most direct drive normally aspirated Avco Lycoming engines is 500°F. Some of the higher powered, more complex engines have a limit of 475°F. Although these are minimum and maximum limits, the pilot should operate the engine at more reasonable temperatures in order to achieve the expected overhaul life of the powerplant. It would be normal during all-year operations in climb and cruise to see head temperatures in the range of 350°F to 435°F.

Sudden cooling of the CHT (known as Shock-Cooling) is a problem that is common with aircraft engines. This is caused by fast descents with little or no power and rich mixtures. This may result in bent pushrods due to exhaust valves sticking, burned valves, spark plug fouling, broken piston rings, cracked cylinders at the spark plug and valve ports and warped exhaust valves. To avoid these problems, do not allow the CHT to cool more rapidly than 1°F every 3 seconds during in-flight operation. The Ultimate Analyzer will automatically detect a Shock-Cooling condition in the normal mode of operation for the cylinder being displayed. When it detects a CHT descending too rapidly the red light over the CHT display will blink.

During climbs, the cylinder head temperatures will rise rapidly until the heat absorbed by the combustion walls is dissipated out the engine's cooling fins. At this point, the CHT will stabilize. Any change in throttle, mixture, cowl, OAT or airspeed will affect the CHT and the rate at which it will change. Since rate and trend information can be interpreted easily on the Ultimate Analyzer's digital display, changing any one of these parameters to stabilize, slow or reduce the CHT is possible with almost immediate results.

The Cylinder Head Temperatures are related to your engine's ability to produce power. If any cylinder has a problem producing power (fouled plug, burned or stuck valve, broken ring, intake leak, plugged injector, timing problem, bad mag, etc.) the CHT for that cylinder will be abnormally high or low depending on the extent of the problem. Each cylinder on your engine operates differently and has a normal operating temperature of its own. The Ultimate Analyzer is capable of being programmed to match each cylinder on your engine. When selecting the following limits, it is assumed your engine currently does not have a problem and is operating properly.

A) Selecting the High CHT Limits: On a hot day with your engine set to 75% power, lean your engine to peak EGT. Record the CHT readings for each cylinder with the cowl flaps closed. Program the High Limit for each cylinder 40°F above the recorded reading for that cylinder.

Some aircraft reach the highest CHT temperatures during a long full throttle climb. If this is the case for your aircraft, record the highest CHT readings for each cylinder during a long climb. Program the High Limit for each cylinder 40°F above the recorded reading for that cylinder.

This High CHT Limit should not be set higher than the maximum limit allowed for your aircraft.

B) Selecting the Lower CHT Limits: The CHT Low Limits should be set to 150°F. Operating your aircraft with CHT's below 150°F is not recommended. The large difference between the combustion temperatures and low CHT temperatures can cause engine damage. Setting the CHT's to this low limit allows you to place the Ultimate Analyzer in the Scan Mode during take-off without getting any warning lights. That way the Ultimate Analyzer can start analyzing your engine during the take-off roll.

C) Selecting the Shock-Cooling Limit: Lycoming recommends your CHT's do not decrease more than 1°F in 3 seconds. It has been E.I.'s experience this is a good number. Set your Shock-Cooling Rate to 3 seconds for a 1°F change.

4. Oil Temperature

As the oil passes through the engine, it is heated. It then passes through the oil cooler and reaches a stable temperature, depending on internal engine temperatures, oil flow (pressure, etc.) and oil cooler efficiency (airspeed, etc.). A change in any of these parameters will cause the oil temperature to increase or decrease. With the 1°F resolution of the Ultimate Analyzer, oil temperature changes can be detected at a glance. This allows the pilot to diagnose many problems that may never be noticed with a less sensitive gauge. Also, with the 1°F resolution of the Ultimate Analyzer some of our customers are attempting to detect excessive wear in the engine bearings.

Maintaining your oil temperatures within operating limits is essential. If the oil exceeds its maximum operating temperature or if it is operated at excessively high temperatures for a long period of time, the oil will break down and it will not possess the necessary lubricating properties to protect your engine. The formula for long engine life is to change your oil at regular intervals and watch your oil temperatures with an accurate gauge that can give you rate and trend information at a glance.

A) Selecting the High Oil Limit: On a hot day with your engine set at 75% power, lean your engine to peak EGT. Record the Oil Temperature reading with the cowl flaps closed. Program the High Limit for 20°F above the recorded reading.

Some aircraft reach the highest Oil Temperature during a long full throttle climb. If this is the case for your aircraft, record the highest Oil Temperature reading during a long climb. Program the High Limit for 20°F above the recorded reading.

This Oil Temperature Limit should not be set higher than the maximum limit allowed for your aircraft.

B) Selecting the Lower Oil Limit: At cold temperatures the viscosity of oil increases. Although synthetic oils will operate at relatively cold temperatures, most oils will not flow well below 50°F. Set the Lower Oil Limit to the minimum allowed operating temperature limit for your aircraft.

5. Outside Air Temperature

The Ultimate Analyzer has two features that make it a valuable tool when measuring outside air temperatures. The first of these features is its superior accuracy and linearity over conventional gauges. Outside air temperatures have a big affect on your aircraft's ability to lift and on engine horsepower. Accurate OAT readings are essential if you are looking for maximum performance from your aircraft.

The second valuable feature is the Ultimate Analyzer's ability to detect small temperature changes (1°F). This gives the pilot rate and trend information (in what direction and how fast the temperatures are changing) at a glance. This is valuable for detecting changing atmospheric conditions and avoiding thunderstorms and icing conditions. It can also help in warm weather to find cooler flying conditions.

Selecting the Higher and Lower OAT limits: If the Higher or Lower OAT Limits are exceeded, the scan will stop and the appropriate "Temp Prob" light will come on. For this reason you may want to disable the Higher and Lower OAT Limits (program them for 000).

6. Carburetor Temperature

Venturi affect and atomization of fuel can cause temperatures in the carburetor to drop 25°F or more. When the atmospheric conditions are right, this temperature drop will cause icing in the carburetor. As icing starts to form, the Ultimate Analyzer will display a temperature near 32°F. To avoid carburetor icing, apply partial carburetor heat to bring the carb temp between 39°F and 49°F. Outside air temperatures below 10°F will not cause carb icing due to the lack of moisture in the air.

A) Selecting the High Carb Temp Limit: The High Carb Temp Limit can be used as a fire detector or detonation deterrent. If the Carb Temp exceeds 150°F for many aircraft the engine can detonate at high throttle settings.

It is not uncommon for an aircraft engine to backfire on start. This is especially true when the battery is low. If this happens and a fire starts in the carburetor, it can cause extensive damage before the problem is noticed. The Ultimate Analyzer can detect this problem almost immediately.

Set the High Carb Temp Limit for 150°F. This is only a recommended limit. As you get to know your engine's normal operating temperatures you may want to adjust this limit accordingly.

B) Selecting the Lower Carb Temp Limit: You may want to set the Lower Carb Temp Limit for 37°F. This is just above the temperature where ice will form. There is, however, a disadvantage to setting the Low Limit for 37°F. If you fly in very cold weather where ice cannot form, the Ultimate Analyzer will show a "Temp Prob" and the automatic scan will stop until the Carb Temp is increased above 37°F. If this is the case, you may want to use partial carb heat or disable the Lower Carb Temp Limit. Setting a limit to 0000 disables that limit.

Operating the Ultimate Analyzer in Your Aircraft

1. Taxi

During taxi most of your engine temperatures will be below the Lower Temperature Limits. Therefore, to avoid any red "Temp Prob" lights, operate the Ultimate Analyzer in the Manual Mode. In the Manual Operating Mode the Lower and Differential Limits are disabled.

2. Run Up

During run up you may want to look at each of your engine temperatures by stepping the Ultimate Analyzer through the channels manually. If you want the Ultimate Analyzer to diagnose your engine automatically, place the Ultimate Analyzer in the Scan Operating Mode. A situation you may encounter by scanning during run up is that some of the engine temperatures (such as EGT's) may not exceed their Lower Temperature Limits. If this is the case, you may want to check your engine using the Manual Mode or program the Lower Temperature Limits to accommodate scanning at run up.

3. Takeoff

Place the Ultimate Analyzer in the Scan Operating Mode during takeoff. For the first few seconds of the takeoff roll you may get a red "Temp Prob" light until the engine temperatures exceed their Lower Temperature Limits. The Ultimate Analyzer will automatically diagnose your engine during takeoff. A red "Temp Prob" light will alert you if the Ultimate Analyzer detects a problem during takeoff.

For the Ultimate Analyzer to diagnose problems it is important the limits be set properly. The golden rule for setting the limits on the Ultimate Analyzer is “No Red Light During Take-Off, Climb or Cruise.” If your engine is operating properly and you’re getting a red light, see “Selecting the Proper Limits” section of this manual.

4. Climb

Leave the Ultimate Analyzer in the scan operating mode during the entire climb. The Ultimate Analyzer will automatically diagnose your engine during the climb. A red “Temp Prob” light will alert you if the Ultimate Analyzer detects a problem. One situation that may occur on non-turbo charged aircraft during a climb is a low EGT warning. As the aircraft climbs the air gets thinner and the engine will run richer. When this happens the EGT temperatures will drop and may violate the Lower EGT Limit. Many Ultimate Analyzer pilots look for this warning to enable them to properly lean during the climb. If you use this method, do not allow the EGT temperatures to exceed 1300°F for throttle settings above 75% power. Refer to the engine and aircraft operator's manual for proper leaning information for your aircraft.

5. Cruise

In cruise you will want to lean your engine. A rich running engine wastes fuel needlessly and tends to run on the rough side, thereby creating vibration, which causes deterioration of engine accessories and engine mounts. Also, proper leaning at cruise and during descent means less spark plug fouling, longer life for the plugs, reduced maintenance costs and a considerable fuel savings. Furthermore, good leaning techniques result in cleaner combustion chambers with fewer lead salt deposits on the pistons and exhaust valves. Under certain conditions, these deposits invite preignition and higher maintenance costs. Proper leaning at cruise during cool or cold weather aids in raising engine and oil temperatures to desirable minimums in order to evaporate the water and acids out of the oil. Water and acids attack the insides of an engine, causing rust and corrosion.

To properly lean your engine perform the following steps:

A) Rough Leaning: Set the Ultimate Analyzer in the Manual Operating Mode and push the “Peak” button below the EGT display. This feature only functions if you are set up to monitor all of your EGT's. Adjust the mixture control from the full rich position to a leaner setting that results in a slight drop in engine RPM or to a setting near lean, as dictated by experience. The mixture control should be left at this setting until the EGT's stabilize. It will take about 20 seconds for the temperatures to stabilize within 1°F. This lag is due to the combustion walls and piston domes increasing in temperature and, therefore, affecting the combustion and exhaust gas temperatures. To correctly lean an engine you must wait for the engine to thermally stabilize. Less sensitive gauges will not pick up these subtle changes, which are important in leaning and diagnosing problems.

B) Precision Leaning: Again press the “Peak” button on the Ultimate Analyzer to find the hottest EGT cylinder. This cylinder may be different than the one you started with. This is the cylinder on which

you should perform your precision leaning. Again, start leaning, only this time making very small adjustments and wait 3 to 5 seconds between adjustments. As you approach peak the exhaust gas temperature will rise much slower until it starts to decrease. When this happens you have reached peak EGT. The 1°F resolution of the digital display will be invaluable in helping you precisely detect peak EGT.

C) Finding The Cylinder That Peaks First: For most engines step B (Precision Leaning) will result in a properly leaned engine. If you find this to be the case with your engine, this step will not be necessary. But if you want to verify you have leaned to the cylinder that peaks first and your engine is operating properly, perform the following with the cylinder found in step B at peak EGT. Slightly enrich the mixture and quickly step through each cylinder. Any cylinder that shows a rising temperature is a leaner cylinder. Check that this cylinder does not rise more than 15°F before it starts decreasing in temperature. If a cylinder rises more than 15°F it may have a problem. See our “Pilot’s Manual for Diagnosing Engine Problems” for more information.

The Ultimate Analyzer’s unique stable display allows you to precisely lean to peak EGT or to a specific temperature below peak for most engines. Peak EGT with a float-type carbureted engine is frequently a vague point because of the fuel/air distribution problems in these lower horsepower engines. As a result, these engines tend to operate smoother at 25°F on the rich side of peak EGT. The fuel-injected engines will provide a more precise peak. Most engines normally operate within an EGT range of 1200°F to 1600°F at cruise power.

Some engine manufacturers allow leaning to peak EGT at 75% power and below on their direct drive normally aspirated engines. For your engine, check the engine manufacturer’s recommended procedures. It is not recommended to lean for peak EGT above 75% power settings. The richer mixture is needed to cool the combustion temperatures and keep the anti-knock capability of the fuel high enough to prevent detonation from occurring at the higher power settings.

After leaning place the Ultimate Analyzer in the “Scn” Operating Mode. The Ultimate Analyzer will automatically and continuously diagnose your engine during the entire cruise portion of your flight. A red “Temp Prob” light will alert you if the Ultimate Analyzer detects a problem with your engine.

6. Descent

During a long gradual descent the Ultimate Analyzer may be left in the Scan Operating Mode, but when the mixture or throttle control is changed, the engine temperatures will drop and the Ultimate Analyzer will see this as a problem. Therefore, during this phase of the descent place the Ultimate Analyzer in the Manual Operating Mode and select one of the front cylinders. In the Manual Operating Mode the Shock-Cooling feature is enabled and the red “Temp Prob” light will blink if a shock-cooling condition is detected.

The versatility of the Ultimate Analyzer’s 36 programmable limits and 1°F resolution makes the Ultimate Analyzer the most sophisticated diagnostic tool you can buy for your aircraft. It is capable of detecting dozens of common engine problems. Setting the proper limits and personalizing the Ultimate Analyzer to your engine is in your hands.

US-8A

INSTALLATION INSTRUCTIONS

S1003911

II 072091

Rev. A 10/4/91

You should have no trouble installing the Ultimate Analyzer in your aircraft. The instrument, probes and cables simply plug together to make hookup easy. Probe and instrument installation is standard and straightforward. The Ultimate Analyzer does not require any programming before installation. Also, it does not use any internal batteries, so once installed the US-8A does not have to be removed. If you run into trouble or have a question, please call (503) 628-9113 and we will be glad to help.

Read step #1 then perform only the remaining steps that apply to your configuration:

1. Important Information and Initial Check Out

1. **The installer and aircraft owner must read the Warranty before starting the installation.** There is information in the Warranty that may alter your decision to install this instrument. **If you do not accept the terms of the Warranty, do not install this instrument.**
2. **If you are not an FAA Certified Aircraft Mechanic familiar with the issues of installing aircraft EGT/CHT instruments, Do Not attempt to install this instrument.** The installer should use current aircraft standards and practices to install this instrument (refer to AC 43.13).
3. **Check that any necessary FAA Approvals (STC's, etc.) are available for your aircraft before starting the installation. An E.I. dealer should have a copy of the current AML. Resolve any issues you may have before starting the installation.**
4. Read the entire Installation Instructions and resolve any issues you may have before starting the installation. This may eliminate any delays once the installation is started.
5. **Inspect the contents of this package prior to installation.** Look for the following items:
 - A) Proper instrument (US-8A-6 for a six-cylinder engine, US-8A-4 for a four-cylinder engine).
 - B) Correct length and number of extension cables (one for each probe).
 - C) Correct number and type of probes.

If you did not receive the proper instrument, probes, cables or hardware for your installation, contact either the dealer you purchased the instrument from or Electronics International Inc. for assistance. In most cases E.I. can exchange parts at no cost. Please have the purchase date, dealer name and serial number of the unit available when you call.

6. **Before starting the installation make sure the unit will fit in the location you intend to install it without obstructing the operation of any controls.**
7. If this instrument is to replace an existing unit in the aircraft, it is the installer's responsibility to move or replace any existing instruments or components in accordance with FAA approved methods and procedures. The following Installation Instructions do not cover moving or the removal of any existing instruments or components.

2. CHT Probe Installation

A single CHT probe should be placed on the hottest cylinder. In a 6-cylinder engine this would be one of the center cylinders. On a 4-cylinder engine this would be one of the back cylinders.

If a second CHT probe is to be installed it should be placed on one of the front unobstructed cylinders. This will allow the US-8A to detect shock-cooling automatically.

Most engines have a port just below the lower spark plug for the CHT probe. If your engine has a primary CHT probe in one of the cylinders, do not remove it. The US-8A is not STC'd as a primary replacement instrument. Select another cylinder for your probe. If you're putting a CHT probe on every cylinder use our P-102 Gasket CHT Probe for your primary cylinder.

3. EGT Probe Installation

A single EGT probe should be installed in the exhaust stack of the leanest cylinder. Each engine has its own characteristics and the leanest cylinder can be different from aircraft to aircraft. As a general rule, the leanest cylinder is one of the back cylinders on a carbureted engine and one of the center cylinders on a fuel-injected engine.

Look at each exhaust stack and determine the best location at which all of the EGT probes can be mounted at the same distance down from the exhaust ports. The ideal location is 1 1/2", but ease of installation should prevail. Drill a 13/64" diameter hole in each exhaust stack. Insert the probe and tighten the hose clamp. As the hose clamp is heated and cooled, it will become loose as it conforms to the exhaust stack. After the first 10 hours of operation, each hose clamp should be retightened.

IMPORTANT NOTE: For Cessna 210's or any aircraft using a slip joint in the exhaust system, install the EGT probes ABOVE OR BELOW THE SLIP JOINT. Installing a EGT probe in the slip joint can damage the probe.

4. TIT Probe Installation

If you currently have a TIT gauge mounted in the aircraft it may be a primary engine instrument. If this is the case you will need to install a secondary TIT probe. The TIT probe should be installed on the inlet of the Turbo-charger one to two inches before the Turbo-charger flange. Drill a 13/64" diameter hole in the exhaust stack. Insert the probe and tighten the hose clamp. As the hose clamp is heated and cooled, it will become loose as it conforms to the exhaust stack. After the first 10 hours of operation, each hose clamp should be retightened.

5. OIL Temperature Probe Installation

Sometimes finding a location for a secondary oil temperature probe can be a problem. The P-120, P-100 and P-128 are all sealed probes appropriate for measuring oil temperature. See the "Probes" section of the price sheet for dimension information.

LYCOMING
IO 320, IO 360 and IO 540

Remove the 5/8" - 18 plug located on the rear engine accessory case above and forward of the oil filter adaptor or oil screen as applicable. Install E.I.'s P-120 Oil Probe with a new oil seal and torque to Lycoming's specifications. Check for oil leaks after the first flight.

All Other Engines
Equipped with a 5/8"-18 Oil Drain Plug

Remove the 5/8" - 18 oil drain plug located on the bottom of the engine. Install E.I.'s P-120 Oil Probe with a new oil seal and torque to specifications. Check for oil leaks after the first flight.

6. Carb Temp Probe Installation

Remove the threaded plug located in the carburetor housing just below the throttle valve. Install the Carburetor Temperature Probe in this hole using a lock washer. Care should be taken not to over-tighten the probe and strip the threads in the carburetor housing.

NOTE: A Carb Temp Probe should be connected to a precision channel on the Ultimate Analyzer. That would be channel 5 or 6 on a US-8A-4 or channel 7 or 8 on a US-8A-6. A three to four degree F error can occur in some instances if the Carburetor Probe is not connected to a precision channel.

7. OAT Probe Installation

Mount the OAT Probe in an appropriate location on the aircraft, using the hardware supplied. The OAT Probe is sensitive to air temperature changes. For this reason, do not mount the OAT probe in the path of the cowl or engine exiting air (i.e., on the belly of the aircraft). Other than this consideration the OAT Probe may be mounted in an air intake vent, on the side of the cowling or anywhere else on the aircraft.

NOTE: An OAT probe should be connected to a precision channel on the Ultimate Analyzer. That would be channel 5 or 6 on a US-8A-4 or channel 7 or 8 on a US-8A-6. A three to four degree F error can occur in some instances if the OAT Probe is not connected to a precision channel.

8. Add any Additional Cables and Mark each Cable

In the installation kit there are two identical pre-wired Extension Cable Harnesses with a Circular Connector. See the Wiring Diagram at the back of this manual. The harnesses have been wired for only the EGT and CHT channels. One of these harnesses is to be used for the 8 channels on the right display and the other is to be used for the 8 channels on the left display. The harnesses are identical and may be used for either display. The ends of each of the extension cables in the harness has a piece of yellow heat shrink marked with its channel number.

Mark the Circular Connector that will be connected to the right and left display.

Any channel used to measure a temperature other than EGT or CHT (TIT, OAT, Carb Temp, etc.) will have a type K thermocouple extension cable lose in the kit. Plug any additional extension cables into the appropriate pins of the Circular Connector (see "Appendix A" at the back of this manual).

Mark each of the appropriate extension cables (on the yellow heat shrink) with the function for which it is to be used (i.e., CHT, EGT, OAT, EGT R., EGT L., etc). An ink pen or marker works well.

E.I. recommends you use the left display starting with channel number 1 for your EGTs and the right display for your CHTs. On a twin-engine aircraft the left display should be used for the left engine and the right display for the right engine (see sample wiring diagrams).

Note 1: Any channel will accept any one of E.I.'s probes.

Note 2: If a cable needs to be removed from a connector, you **must** use an extraction tool. This tool may be purchased from E.I.

9. Route the Circular Connectors

Do not continue with this step unless each Extension Cable has been marked as described in step 8.

Starting from under the instrument panel, route the Circular Connectors on both Extension Cable Harnesses and on the Connecting Wire Harness up to the instrument mounting location (see the Wiring Diagram at the back of this manual). Place the Circular Connectors 9 inches back from the front panel. Tie wrap the harnesses in place approximately one foot back from the Circular Connectors. This will allow the harnesses to be flexible and accommodate varying lengths in instrument wires.

10. Route Each Extension Cable

Starting from under the instrument panel, route each Extension Cable to its appropriate probe. If new connectors are to be installed on the ends of the cables, you may want to pull any excess cable length through the fire wall and cut it off at this time. However, it is recommended you leave some extra wire length under the instrument panel for later modifications. **You may cut any or all cables to any length without any affect to the accuracy of the instrument.** The Extension Cables and probe wires are made of type K thermocouple wire that must not be substituted or extended with regular copper wire. Also, it is important these wires not be kinked (i.e., **do not bend the wires on a radius less than 1 inch.**)

Connect each probe to its associated Extension Cable using the supplied OLC-1 Overlap Connectors. See OLC-1 Installation Instructions for details. When tie wrapping these cables down, be sure there is no strain or pull on the cable against the probe or connectors. Dress each cable up to the instrument keeping them away from any hot areas such as exhaust stacks, cylinder heads, etc.

Tie off any excess cable under the instrument panel. **Be sure these cables do not obstruct the freedom of travel of any controls.**

11. Hook Up Connecting Wires

Connect the red wire in the Connecting Wire Harness to the 12 or 24 volt bus via a 1 amp fuse or circuit breaker (see the Wiring Diagram at the back of this manual). Connect the black wire to ground. Connect the white/brown to the 12V bus (leave it open for a 24V system). Connect the white/red wire to the 24V bus (connect it to ground for a 12V system). Connect the white/orange wire to the Panel Light Rheostat.

Tie off any excess cable under the instrument panel. Be sure these cables do not obstruct the freedom of travel of any controls.

12. Instrument Installation

Install the instrument from behind the instrument panel using 6 x 32 screws supplied in the accessory kit.
DO NOT USE SCREWS LONGER THAN 1/2".

If this instrument is to be mounted directly under a speaker you will need to install a magnetic shield. This is a U shaped piece of steel sheet metal. Contact E.I. Inc. for details.

Connect all the Circular Connectors to the Ultimate Analyzer in the following manner:

- A)** Push the two mating connectors together and twist them until they snap into position.
- B)** Turn the locking ring on the instrument connector clockwise (1 1/2 turns) until it locks into position.

13. System Ground Test

A) Turn the master switch on and look for a near ambient temperature reading on each channel. If the instrument does not power-up (display a reading), check the power and ground leads (red and black leads) for an open, loose or poor connection.

If you suspect any channel is not receiving a signal remove the probe from the engine (leaving it connected to the Extension Cable) and apply a temperature to it. Look for an increase in reading on the display for that channel. Check the other channels for an increase in reading. You may have connected the probe to the wrong Extension Cable. If the reading is decreasing, your may have reversed the connectors on the Extension Cable leads (the yellow wire on the probe must connect to the yellow wire on the Extension Cable).

B) Start the engine and check each channel for a proper reading. On the ground EGTs will read around 900°F and CHTs will read around 200°F. If you suspect any channel is not receiving a signal properly, see step A of the “Troubleshooting” section of this manual.

C) If programming is required, see the Operating Instructions of this manual. The initial factory programmed settings on each display are as follows:

- 1. 8 High Limits ----- 1650°F
- 2. 8 Low Limits ----- 0000°F
- 3. 1 Diff. Limit ----- 200°F
- 4. 1 Shock-Cooling Rate ---- 3 Seconds/°F
- 5. Scan Rate ----- 2 Seconds per Channel
- 6. Last Channel Scanned ---- 8
- 7. Analyzer Channels ----- 1-6

Any one of these 40 programmable limits may be changed from the front panel at any time.

US-8A

Wiring Diagram

WD 1001911

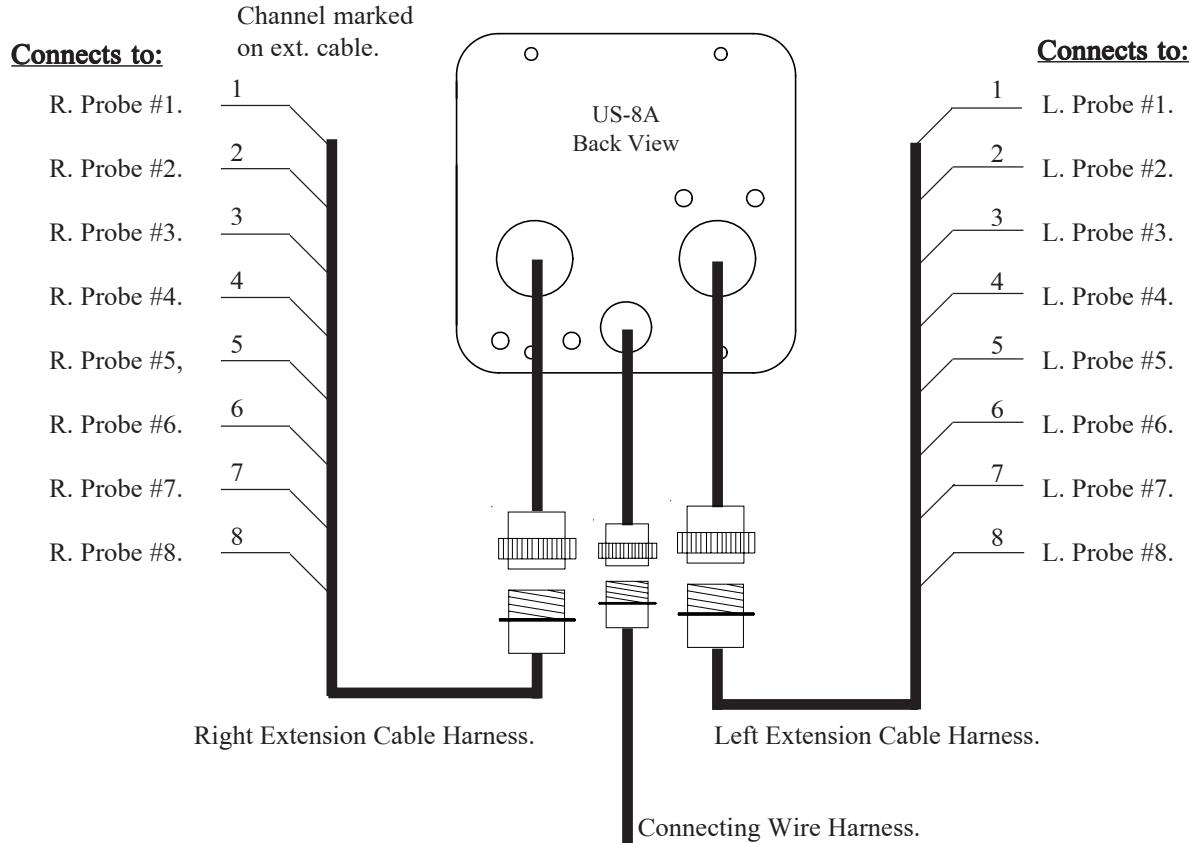

Note: Any channel will accept any one of E.I.'s probes.

Note: Varying cable lengths will not affect accuracy.

Note: For a twin-engine installation use the left channels for the left engine and the right channels for the right engine.

Note: The Right and Left Extension Cable Harnesses are identical.

	<u>Description</u>	<u>Connects To:</u>
White/Brown	12V Back Light.	12V Bus.
White/Red	24V Back Light.	24V Bus (Gnd for 12V system).
White/Orange	LED Dimming.	Panel Light Rheostat.
Red	Power Lead.	12/24 Volt Bus. via 1 amp fuse.
Black	Ground Lead.	Ground
White/Yel	(Optional) External Warning Control Line. Can be connected to a relay to control an external light, buzzer, etc. This line grounds when a Red Warning Light is on. Current must be limited to 2/10 amp maximum.	

US-8A Sample Wiring Diagram For Single 6-Cylinder Engine Aircraft

WD 1001913

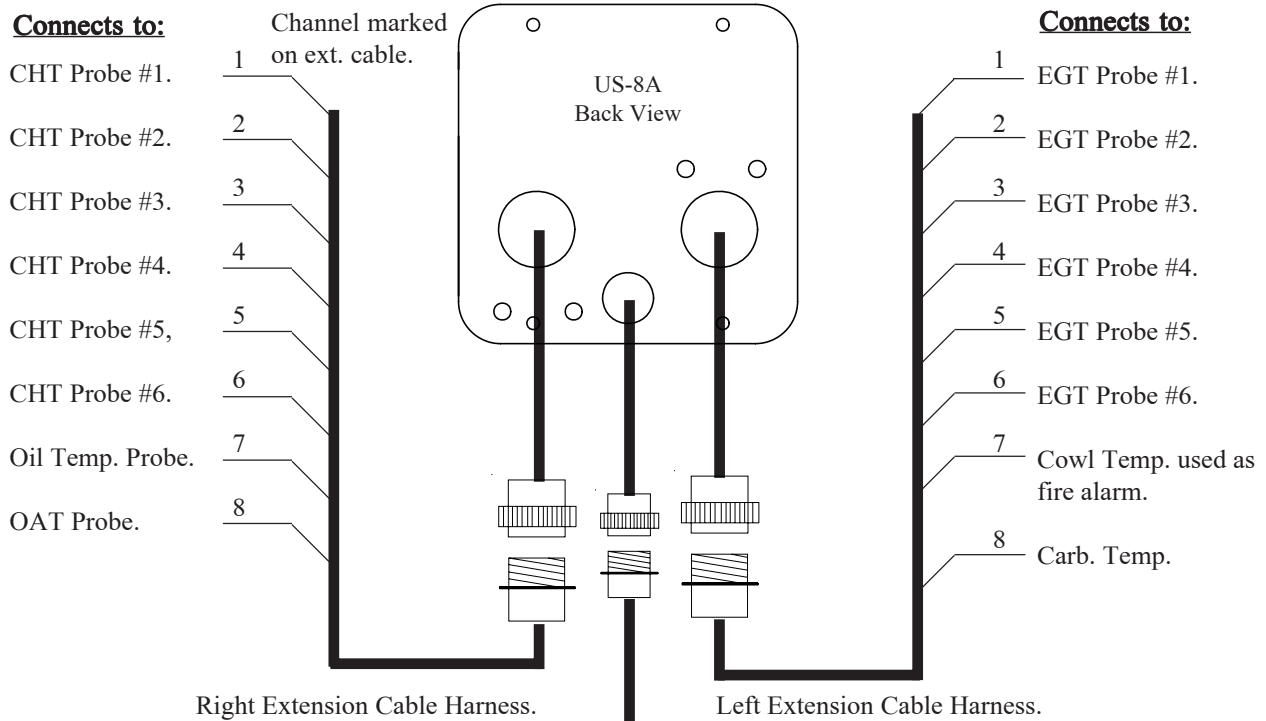

Connecting Wire Harness.

Note: Any channel will accept any one of E.I.'s probes.

Note: Varying cable lengths will not affect accuracy.

Note: For a twin-engine installation use the left channels for the left engine and the right channels for the right engine.

Note: The right and left extension cable harnesses are identical.

	<u>Description</u>	<u>Connects To:</u>
White/Brown	12V Back Light.	12V Bus.
White/Red	24V Back Light.	24V Bus (Gnd for 12V system).
White/Orange	LED Dimming.	Panel Light Rheostat.
Red	Power Lead.	12/24 Volt Bus. via 1 amp fuse.
Black	Ground Lead.	Ground
White/Yel	(Optional) External Warning Control Line. Can be connected to a relay to control an external light, buzzer, etc. This line grounds when a Red Warning Light is on. Current must be limited to 2/10 amp maximum.	

US-8A Sample Wiring Diagram For Twin 6-Cylinder Engine Aircraft

WD 1001914

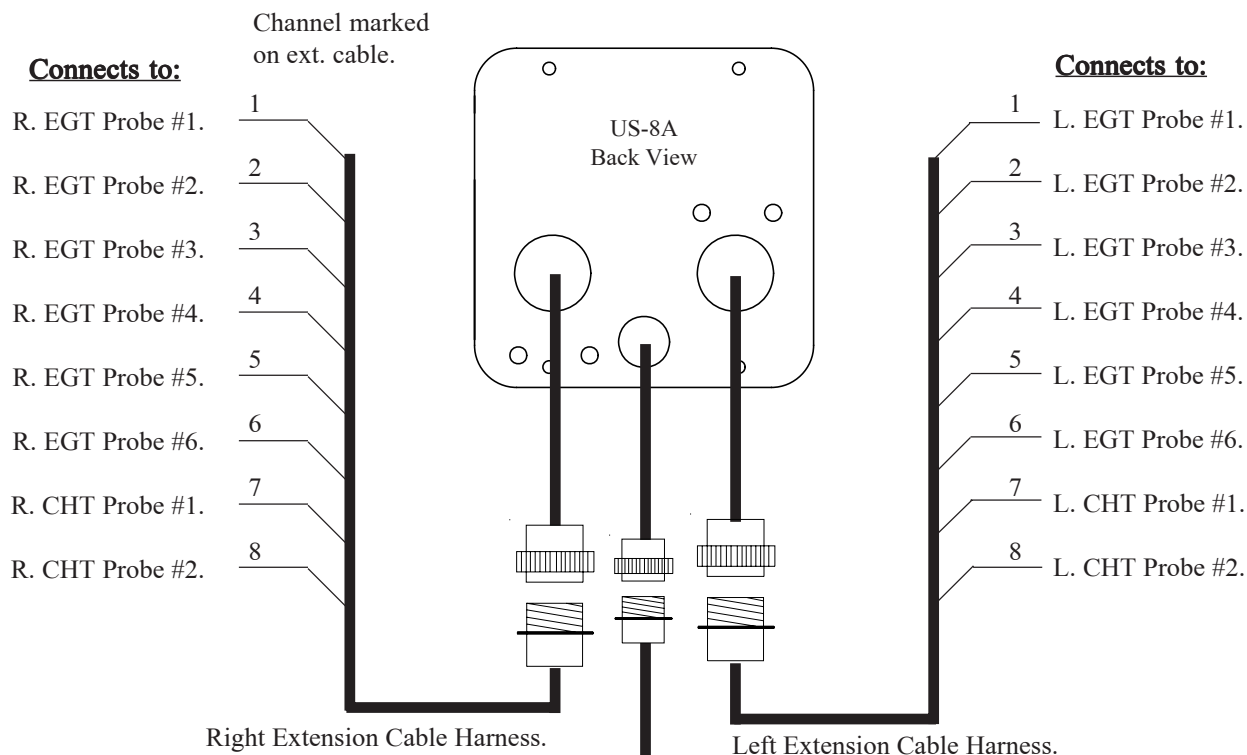

Note: Any channel will accept any one of E.I.'s probes.

Note: Varying cable lengths will not affect accuracy.

Note: For a twin-engine installation use the left channels for the left engine and the right channels for the right engine.

Note: The Right and Left Extension Cable Harnesses are identical.

	Description	Connects To:
White/Brown	12V Back Light.	12V Bus.
White/Red	24V Back Light.	24V Bus (Gnd for 12V system).
White/Orange	LED Dimming.	Panel Light Rheostat.
Red	Power Lead.	12/24 Volt Bus. via 1 amp fuse.
Black	Ground Lead.	Ground
White/Yel	(Optional) External Warning Control Line. Can be connected to a relay to control an external light, buzzer, etc. This line grounds when a Red Warning Light is on. Current must be limited to 2/10 amp maximum.	

TROUBLESHOOTING SUGGESTIONS

T 1004911

10/4/91

Because high reliability is designed into Electronics International's equipment, there is no reason to put up with poor operation. We have few problems with our probes, cables and units and installation is simple. Usually fixing a problem is just a matter of inspecting the installation at a few key points.

Strategy

If you have more than one problem, **FIX ONE PROBLEM AT A TIME**. Trying to fix all of them at once can be confusing and misleading. In many cases fixing one problem first will lead you to the solution for fixing all of the problems. Therefore, take one problem on one channel and proceed with the following:

A. Instrument Check Out

If there is an identical symptom on each channel, then the instrument may have a problem. But if even one channel of the instrument is operating properly, the instrument probably does not have a problem. A good method to test the instrument is to remove all the Extension Cables by disconnecting the Extension Cable Circular Connector. Then look for a reading on all channels to be near cabin temperature. The only inputs the Ultimate Analyzer requires to operate properly and measure cabin temperature is power (red lead) and ground (black lead). Check the power and ground leads for proper connection (pull on the wire at each connector).

NOTE: Few problems turn out to be the instrument.

B. Probe Check Out

There are two good methods of testing a probe. Perform one or both of the following:

1. A probe can be tested with an ohmmeter. Disconnect the probe from the Extension Cable. When testing the resistance between the connectors, the probe should measure a "short" (less than 5 ohms). When measuring from one lead (either lead) of the probe to the probe sheath (metal tip), there should be an "open" (10k or greater).
2. Another method of checking a probe is to plug the suspected bad probe into a channel that is working properly. If the problem follows the probe, you have a defective probe.

C. Extension Cable Check Out

With the Extension Cable connected to the Ultimate Analyzer, remove the probe from the suspected bad Extension Cable. Set the Ultimate Analyzer to the proper channel and look for a near cabin temperature reading on the Ultimate Analyzer. A very high or low reading indicates a short to ground in the cable. Next, connect an ohmmeter, set to 10K range, to the open probe ends of the suspected bad Extension Cable. Set the Ultimate Analyzer to the proper channel and look for a very high (+ or -) reading. A near cabin temperature reading or no change in reading indicates an open in the cable or its connectors. Also, look for a reading on the ohmmeter around 12K ohms. Most problems of this kind are usually one of the following:

1. **Improper OLC-1 Connections:** Pull on wires installed in the Over-Lap Connector to check the connection. You may have insulation in the overlap area. Remove the wires from the OLC-1 and inspect.
2. **Broken Wire:** A wire can be broken from a too-tight tie-wrap or by repeatedly flexing the wire. Inspect the wires for a break. Note: A wire can be broken while the insulation is still intact.
3. **Cable Chafed to Ground:** If a cable is routed around a metal object, it will over time chafe the wire and short to the object. Inspect the wires for chafing.

SPECIFICATIONS and OPERATING FEATURES

S1004911

10/4/91

Model: US-8A

Weight: Unit only: 19 oz., One probe and 6 foot cable: 3.5 oz., One Probe and 20 foot cable: 7 oz.

Environmental: Meets TSO C43a

Power Requirements: 7.5 to 30 Volts, 1/10 Amp.

Display: LCD's (viewable in direct sunlight), with 12 and 24 volt backlight control wires for night operation (channel indicators dim when your instrument panel lights are turned on).

Display Temperature Range: 1999°F to -1999°F

Accuracy: 1/2% in accordance with TSO C43a.

Resolution: 1°F (with enhanced stability and response circuits).

Power-up Test: Flashes red Temp Prob lights during power-up if circuits are operating properly.

Probes: Type K, Ungrounded (for improved accuracy, stability and reliability).

Extension Cables: Type K, any length or size (you may use your existing type K cables to reduce cost and installation time).

Channels: Maximum of 16 Channels, 8 for each display. The number of channels to be used is programmable (2 to 8 per display) from the front panel.

Analyzer Channels: 1 through 8 (EGT and/or CHT), Programmable from front panel.

Scan Rate: Programmable from the front panel for a 2 to 9 second delay per channel.

Peak Locate: Finds hottest analyzer channel within 1°F for the right and left displays.

Hottest Cylinder Indicator: Indicates hottest analyzer channel during scan within 1°F (lights a bar high in the display).

High Limits: Programmable in 1°F increments from 1°F to 1999°F. Each channel for each display may be programmed individually from the front panel.

Low Limits: Programmable in 1°F increments from 1°F to 1999°F. Each channel for each display may be programmed individually from the front panel.

Differential Limit: Programmable in 1°F increments from 1°F to 1999°F from the front panel. One limit for each display.

Specifications and Operating Features

Shock-Cooling: Programmable from 1 to 9 Seconds/°F. One limit for each display.

“Temp Prob” Warning Lights: Lights for the following conditions:

- A. Any channel over the High Limit. Also exhibits a high bar in the display.
- B. Any channel under the Low Limit (in the scan mode only). Also exhibits a low bar in the display.
- C. Any time the difference between the hottest and coldest analyzer channel exceeds the differential limit (in the scan mode only). Also flashes a high and low bar in the display.
- D. Blinks the Temp Prob light any time the displayed channel cools faster than the Shock-Cooling limit (in normal mode only, not scan mode). This problem is only displayed for channels with a High Limit programmed between 300°F to 600°F and displaying a temperature between 300°F and 600°F.

Appendix A

Adding a Channel to the US-8A

If you have an unused channel and would like to add an extension cable to your instrument, perform the following steps:

1. Order an XCS Extension Cable at the proper length from Electronics International Inc.
2. Disconnect the Circular Connector from the back of the US-8A.
3. Insert the the XCS Extension Cable into the Circular Connector at the proper location (see below). Once these connectors are installed do not try to remove them without an extraction tool. Unless an extraction tool is used you can damage the Circular Connector. An extraction tool may be purchased from Electronics International Inc.
4. Follow the appropriate steps in the Installation Instructions for mounting the probes and routing the Extension Cables.
5. Reconnect the Circular Connector to the back of the US-8A.

Extension Cable Harness
Back View (wire side)

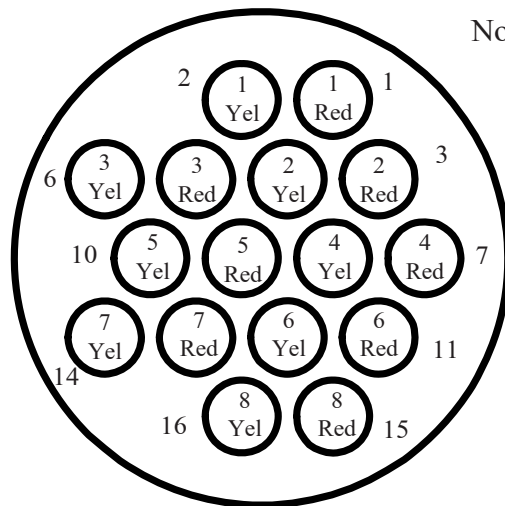

Note: 1 Red = Channel #1 Red wire.
1 Yel = Channel #1 Yel wire.

Appendix B

US-8A Circular Connectors

Extension Cable Harness, Back View (wire side)

OR

Instrument Connector, Front View

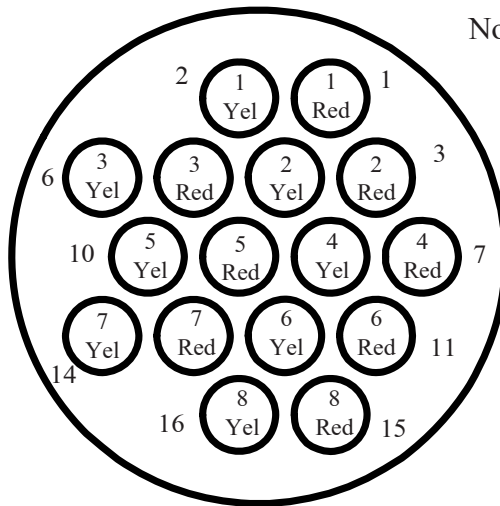

Note: 1 Red = Channel #1 Red wire.
1 Yel = Channel #1 Yel wire.

Connecting Cable Harness, Back View (wire side)

OR

Instrument Connector, Front View

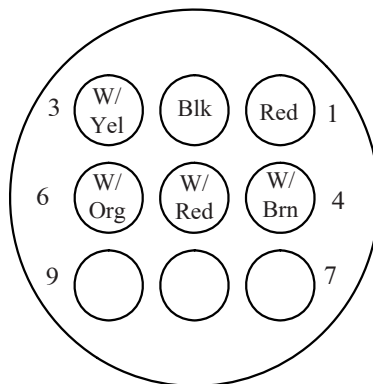

Note: See Wiring Diagram for hook up information.

United States of America
Department of Transportation — Federal Aviation Administration
Supplemental Type Certificate

Number SA4302NM

This certificate, issued to Electronics International, Inc.

*certifies that the change in the type design for the following product with the limitations and conditions therefor as specified hereon meets the airworthiness requirements of Part * of the * Regulations.*

Original Product — Type Certificate Number: * *See attached Approved Model List (AML) No.
Make: * SA4302NM for list of approved airplane models
Model: * and applicable airworthiness regulations.

Description of Type Design Change: Installation of Electronics International, Inc. Model SR-8 or Model US-8 Digital Automatic Engine Analyzer (THE SMART SCANNER) in accordance with Electronics International, Inc. Installation Instructions No. II 012881, dated 1/28/88 (for SR-8), or Installation Instructions No. II 072091, dated July 20, 1989 (for US-8), or later FAA approved revisions.

NOTE: The Model SR-8 and Model US-8 listed here are designed as engine analyzers and are not primary instruments.

Limitations and Conditions: Approval of this change in type design applies to the above model aircraft only. This approval should not be extended to other aircraft of this model on which other previously approved modifications are incorporated unless it is determined that the relationship between this change and any of those other previously approved modifications, including changes in type design, will introduce no adverse effect upon the airworthiness of that aircraft. A copy of this Certificate, AML No. SA4302NM, and the above mentioned Installation Instructions must be maintained as part of the permanent records for the modified aircraft.

This certificate and the supporting data which is the basis for approval shall remain in effect until surrendered, suspended, revoked, or a termination date is otherwise established by the Administrator of the Federal Aviation Administration.

Date of application: February 25, 1988

Date issued:

Date of issuance: April 21, 1988

Date amended: October 13, 1989

By direction of the Administrator



Stewart K. Miller
(Signature)

Assistant Manager, Seattle
Aircraft Certification Office

(Title)

Any alteration of this certificate is punishable by a fine of not exceeding \$1,000, or imprisonment not exceeding 3 years, or both.

This certificate may be transferred in accordance with FAR 21.47.

FAA Approved Electronics International, Inc. Approved Model List (AML) SA4302NH for Installation Of Electronics International Digital Automatic Engine Analyzers										Issue Date: April 21, 1988	
Item	Aircraft Make	Aircraft Model	Original Certificate Number	Certification Basis for Alteration	FAA Sealed Drawings		Installation Instructions	Date	AML Amend. Date		
					Number	Rev. No.					
10.	Beech Aircraft Corp.	B178, B17L, SB17L, B17R, C17R, 18 Series, 19, 23, 24, 25, 35, 36 Series, 3415, 543, 544, 60 Series, 65, 70, 90 Series, 76 Series, 77 Series, F90 Series, 95, 95.5, 96, 58 Series, 99, 100 Series, 200 Series, 200C, 1900C, 1900C Series	ATC 560, ATC 579, ATC 602, ATC 604, A-757, -765, A1CE, 3415, 543, 544, A12CE, 3A20, A29DE, A30DE, A31CE, 3A16, A33CE, A14CE, A24CE, A24CE Series, A24CE Series	CAR 4a, CAR 4a, CAR 4a, CAR 4a, CAR Part 3, CAR Part 3, CAR Part 03, CAR Part 3, FAR Part 23, CAR 3, Part 23, Part 23, Part 23, CAR Part 3, FAR Part 23, FAR Part 23, FAR Part 23, FAR Part 23, FAR Part 23, FAR Part 23	T0031381	C 10/6/89	11012881, 11072091	1/28/88, 7/20/89			03/05/93
11.	Bell Helicopter Textron	47 Series, 204&205 Series, H1 SM, 212 Series, 214 Series, 222 Series, 206 Series	H-1, 2H3, 2-H1, H1 SM, H4 SM, H6 SM, H9 SM, H2 SM	FAR Part 23, CAR 7, FAR Part 29, FAR Part 29, FAR Part 29, FAR Part 29, FAR Part 29						5/11/92	
12.	Bellanca Aircraft Corp.	7 Series, 11 Series, 14, 17, 8 Series, 300 Series, 400 Series	A-759, A-761, 796, A-18CE, A21CE, ATC328, ATC319	CAR 4a, CAR 4a, CAR 3, FAR Part 23, FAR Part 23, ATC328, ATC319						10/13/89	
13.	British Aerospace	Twin Pioneer Series 2&3, Beagle B206, Beagle B121 Series, 1, 2, 1, 83	7A7, A11EU	CAR 10, FAR 21.29 (CAR 3)						10/13/89	
14.	Cessair Aircraft Corp.	Navion 480	2A2	CAR 3						5/11/92	

FAA Approved Electronics International, Inc. Approved Model List (AML) SA4302NH for Installation Of Electronics International Digital Automatic Engine Analyzers										Issue Date: April 21, 1988	
Item	Aircraft Make	Aircraft Model	Original Certificate Number	Certification Basis for Alteration	FAA Sealed Drawings		Installation Instructions	Date	AML Amend. Date		
					Number	Rev. No.					
1.	Aerocar Inc.	I	4A16	CAR 3	T0031381	C 10/6/89	11012881, 11072091	1/28/88, 7/20/89		10/13/89	
2.	Aeronca Inc. (also see trytek)	C-2 Series, C-3 Series, K&S0 Series, L Series, 15 Series	ATC 351, A 396, 688, 676, ATC 596 & 614, 614, A602	Aero Bul. 7-A, 688, 676, ATC 596 & 614, CAR 3							
3.	Aerospaciale (Also see Socato)	SE 3160, Alouette-III, SA 315, SA 316, SA 319 Series, 262A, A6 EU, SN-601, SA 350 & 360 Series, SA 365 Series	H1 IN, H1 IN, H1 IN, H1 IN, H1 IN, H1 IN, A37 EU, H8 EU, H10 EU	CAR 10, CAR 10, CAR 10, CAR 10, CAR 10, CAR 10, FAR 21.29, FAR 21.29, FAR 21.29						5/11/92	
4.	Aircraft Associates Inc.	J-2	ATC 620	ATC 620						10/13/89	
5.	Air Tractor Inc.	AT-300, -300, -302, -400	A9SW	FAR 21.25 (a)(1)	TD121161					5/11/92	
6.	Artic Aircraft Co.	S-1A Series, S-1B Series	A737, A754	CAR 4a, CAR 4a						10/13/89	
7.	Ayres Corp.	S-2R, S Series, 600 Series, S28Series	A3SW, A4SW, ZN9, 2A7, A3SW	CAR 3, CAR 8, 8.10(a)(1), 8.10(a)(1), CAR 3						5/11/92	
8.	Ballaer	Funk Series	2-564	CAR 04.031						10/13/89	
9.	Balloon Works, The	Fire Flies	A14s0	FAR 31							

FAA Approved Electronics International, Inc. Approved Model List (AML) SAA302NM for Installation Of Electronics International Digital Automatic Engine Analyzers										Issue Date: April 21, 1988	
Item	Aircraft Make	Aircraft Model	Original Certificate Number	Certification Basis For Alteration	FAA Sealed Drawings		Installation Instructions		AML Amend. Date		
					Number	Rev. No.	Number	Date			
15.	Cessna Aircraft (Also see Retins)	120, 140 Series 150, 152 Series 170 Series 172, 175 Series 177 Series 180 Series 182, 185 Series 188 Series 190, 195 Series 207 Series 210 Series 303, 305 Series 310 Series 320, 335, 340 Series 337, 401, 402, 411, 414, 421, 425 Series 404	A768, 5A2 3A19 A799 3A12, 3A17 A13CE, A20CE 5A6 3A13, 3A24 A-761 A9CE A-790 A4CE A16CE 3A21 5A5, 3A14 3A10 3A25 A2CE A6CE A7CE A25CE	CAR 4a CAR 3 (CAR 4a) CAR Part 3 CAR Part 03 CAR Part 3 CAR Part 23 CAR Part 3 CAR Part 3 CAR 4a FAR Part 23 CAR 3 CAR Part 3 FAR Part 23 CAR Part 3 CAR Part 3 CAR 3 CAR Part 3 CAR 3 CAR Part 3 CAR Part 3 CAR Part 3 CAR Part 3 CAR Part 3	10031381	C 10/6/89	11012881 11072091	1/28/88 7/20/89	10/13/89		
16.	Christen Industries Inc.	S-1, S-2, Series (Pitts)	A850	FAR 21 (FAR 23)	"	"	"	"	5/11/92		
17.	Child Doyle F.	S-1, S-2 (Pitts)	A850	FAR 21 (FAR 23)	"	"	"	"	10/13/89		
18.	Consolidated Aeronautics	Colonial C. Series, Lake LA Series	1A13	CAR 03	"	"	"	"	"		
19.	De Havilland	DH Series	A8EU 2-429 2-333 7A10 A-816 A-807	FAR 21-29 FAR 21-29 CAR 10 CAR 10 CAR 10	"	"	"	"	1/10/91 5/11/92 " "		
20.	Enstrom Helicopters	F Series 280 Series	A9EA AR-33 AR-13 1A19 HICE	CAR 3 CAR 8 CAR 8 CAR 10 CAR Part 6	"	"	"	"	10/13/89 5/11/92 "		

FAA Approved Electronics International, Inc. Approved Model List (AML) SAA302NM for Installation Of Electronics International Digital Automatic Engine Analyzers										Issue Date: April 21, 1988	
Item	Aircraft Make	Aircraft Model	Original Certificate Number	Certification Basis For Alteration	FAA Sealed Drawings		Installation Instructions		AML Amend. Date		
					Number	Rev. No.	Number	Date			
21.	Great Lakes	ZT Series	A1C36A A1C-167 2-3339 A1C228 A18EA	ATC36A A1C-167 2-3339 A1C228 FAR 23	10031381	C 10/6/89	11012881 11072091	1/28/88 7/20/89	5/11/92 10/13/89		
22.	Gulfstream Aerospace	111 Series 112 Series 114 Series	1150 A1250 A1250	FAR 23 (FAR 36)	"	"	"	"	5/11/92		
23.	Gulfstream American	Grumman: G-764 G Series AA Series CA Series 500 Series 111 Series 112 Series 114 Series	1A16 1A17, A12EA A14EA A1250 6A1 A1150 A1250 A1250	CAR 8, 10 (b)(1) CAR 4b FAR 23 CAR 3 CAR 3 FAR 23 FAR 23 FAR 23 (FAR 21) (FAR 36)	"	"	"	"	10/13/89		
24.	Helio Aircraft LTD (Navion)	H-250 H-295 1A8 HT-295 1A8 H-391 H-391B 1A8 H-395 H-395A 500	1A8 H-250 1A8 HT-295 1A8 H-391 H-391B 1A8 H-395 H-395A 500	CAR 3 CAR 3 CAR 3 CAR 3 CAR 3 CAR 3 CAR 3 CAR 3 CAR 3 CAR 3	"	"	"	"	10/13/89		
25.	Killer Aviation	UH-12 Series	4H12	CAR 6	"	"	"	"	5/11/92 10/13/89		
26.	Rugles Helicopters	300 Series 269 Series	4H12	CAR Part 6	"	"	"	"	"		
27.	RYTES	H-2, H-4	2H2	CAR Part 6	"	"	"	"	"		
28.	Industrie Aeronautiche Meccaniche (See Piaggio)	PD 808/526 P-166 Series	A12EU 7A4	FAR 21-29 CAR 10	"	"	"	"	3/05/93 "		
29.	Lake	See consolidated Aeronautics	3A23	CAR Part 3	"	"	"	"	"		
30.	Maula Air-craft Corp.	M Series	A-807 A-618	CAR 4 CAR 4	"	"	"	"	1/10/91		
31.	McDonnell Douglas	DC3 Series DC4 Series	2A3 A6SW	CAR 3 CAR 3	"	"	"	"	10/13/89 5/11/92		

FAA Approved Electronics International, Inc. Approved Model List (AML) SA4302NM Installation Of Electronics International Digital Automatic Engine Analyzers										
Item	Aircraft Make	Aircraft Model	Original Type Certificate Number	Certification Basis for Alteration	FAA Sealed Drawings		Installation Instructions		AML Amend. Date	
					Number	Rev. No.	Number	Date		
					T0031381	C 10/6/89	11012881 11072091	1/28/88 7/20/89		
33.	Navion	See Comiar Ryan and Thompson								
34.	North American Aviation	AT-6	A-2-575	CAR 4a	"	"	"	"	10/13/89	
35.	Partenavia Costruzioni Aero-nautiche	P68 Series	A31EU	FAR 21,29 (FAR 23)	"	"	"	"	"	
36.	Piaggio (See Industrie)	P-136-L Series	A 813	CAR 10					03/05/93	
37.	Pilatus Britten-Norman	BN Series	A17EU	FAR 21, 29, FAR 23	"	"	"	"	10/13/89	
38.	Piper Aircraft Corp.	2 Series J3 Series	ATC595 ATC660 A-691 A-692 A-698 695 A-703 A-704,721 A-725 A-780 A-797 A-800 A-805 A-805 PA17Series PA18Series AR-7 PA20Series PA22Series PA23Series PA24Series PA25Series 2A8, 2A10 2A13 PA28Series PA 20,39, PA 30 Series PA31Series ABEA PA32Series A330 A750 PA34Series A950 A1050 PA38Series PA44Series A1950 PA46Series PA-60-600 PA-60-601 PA-60-601P PA-60-602P PA-60-700P	ATC595 ATC660 A-691 A-692 A-698 695 A-703 A-704,721 A-725 A-780 A-797 A-800 A-805 A-805 PA17Series PA18Series AR-7 PA20Series PA22Series PA23Series PA24Series PA25Series 2A8, 2A10 2A13 PA28Series PA 20,39, PA 30 Series PA31Series ABEA PA32Series A330 A750 PA34Series A950 A1050 PA38Series PA44Series A1950 PA46Series PA-60-600 PA-60-601 PA-60-601P PA-60-602P PA-60-700P	"	"	"	"	"	5/11/92 10/13/89

FAA Approved Electronics International, Inc. Approved Model List (AML) SA4302NM Installation Of Electronics International Digital Automatic Engine Analyzers										
Item	Aircraft Make	Aircraft Model	Original Type Certificate Number	Certification Basis for Alteration	FAA Sealed Drawings		Installation Instructions		AML Amend. Date	
					Number	Rev. No.	Number	Date		
					T0031381	C 10/6/89	11012881 11072091	1/28/88 7/20/89		
39.	Pitts	See Child								
40.	Prop-Jets Inc. (Aero Commander)	200 Series	3A18	CAR 3 CAR 3 CAR 3	"	"	"	"	10/13/89	
41.	Reims Aviation (Cessna)	172Series 150Series 182Series 337Series 177Series	A4EU A18EU A13EU A42EU A23EU A26EU	CAR 10 FAR 21,29 (CAR 3) FAR 21,29 CAR PART 3 FAR 21,29 (FAR 23) FAR PART 23	"	"	"	"	"	
42.	Robinson Helicopter	R 22	H10ME	FAR 27	"	"	"	"	"	
43.	Rockwell International (Also see Avres)	111Series 112Series 500,520,560,680,681,690,695,720	A1250 A750 6A1	FAR 23 (FAR 36) FAR 23 CAR 3	"	"	"	"	1/10/91	
44.	Rust, Robert F. (Chipmunk)	21,22 Series	A44EU	FAR 21,29	"	"	"	"	10/13/89	
45.	Ryan Aero-nautical Co.	SQU-145 ST Series	658 ATC 571 A-749	CAR 4a CAR 4a	"	"	"	"	5/11/92	
46.	Ryan Aircraft Corp.	B Series	ATC 25	CAR 4a	"	"	"	"	5/11/92	
47.	Sikorsky Aircraft	H19 Series S-39Series S-41-B S-42Series S-51Series S-52Series S-55Series S-58Series S-62A Series S-64Series S-76Series	HR150 ATC-375 2-286 ATC-475 752 K-2 K-3 1H4 S-61Series 1 H15 S-62A 1 H13 S-64Series H1EA H1ME	FAR 21,25 FAR 21,25 Aero. Sub-FA CAR 4a CAR 6 CAR 6 CAR 6 S-61Series CAR 7 CAR 7 CAR 7 CAR 8 FAR 29	"	"	"	"	5/11/92	
48.	Socata Group Aero-Spatiale	TB9,10, 20,21	A51EU	FAR 29	"	"	"	"	1/10/91	

FAA Approved Electronics International, Inc. Approved Model List (AML) SA4302HM for Installation Of Electronics International Digital Automatic Engine Analyzers										
Item	Aircraft Make	Aircraft Model	Original Type Certificate Number	Certification Basis for Alteration	FAA Sealed Drawings		Installation Instructions		AML Amend. Date	
					Number	Rev. No.	Number	Date		
49.	Steamer Aircraft	C3 Series 4 Series 6 Series	ATC55, 2-150 2-425 ATC251 2-155 ATC-305 ATC-292 ATC459	ATC55 2-150 2-425 ATC251 2-155 ATC-305 ATC-292 ATC459	"	"	11012881 11072091	1/28/88 7/20/89	10/13/89	
50.	Stinson	SN Series	ATC16 ATC136 ATC48 ATC45 ATC61 ATC94 ATC98 ATC99 ATC330 ATC580 ATC594 ATC608 ATC609 ATC621 ATC625 ATC640	ATC16 ATC136 ATC48 ATC45 ATC61 ATC94 ATC98 ATC99 ATC330 ATC580 ATC594 ATC608 ATC609 ATC621 ATC625 ATC640	"	"	"	"	"	
51.	Stol Amphibian Corp.	UC-1 (Twin-Bee) Republic RC-3	A6EA A-769	CAR 3 CAR 03	"	"	"	"	10/13/89 6/06/90	
52.	Swift Museum Foundation	GC Series	A-766	CAR 4a	"	"	"	"	5/11/92	
53.	Taylor- craft Aviation	BC & BCS Series 19 & F21 DC Series BF Series BL Series	A-696 1A9 A746 A-699 A-700	CAR Part 04 CAR Part 3 CAR 4a CAR 4a CAR 4a	"	"	"	"	10/13/89	
54.	Thompson, Jimmie, Enterprise (Kevion)	A through Z Series	A-782	CAR 3	"	"	"	"	"	
55.	Trytek, E.J.	Aeronca CF, KC K, KS	ATC 655 A-634	Aero Bul. 7a Aero Bul. 7a	"	"	"	"	5/11/92	

FAA Approved Electronics International, Inc. Approved Model List (AML) SA4302HM for Installation Of Electronics International Digital Automatic Engine Analyzers										
Item	Aircraft Make	Aircraft Model	Original Type Certificate Number	Certification Basis for Alteration	FAA Sealed Drawings		Installation Instructions		AML Amend. Date	
					Number	Rev. No.	Number	Date		
56.	Univer Aircraft Corp. (Mooney) (Erco) (Stinson) (Alon) (Mooney) (Erco)	108 Series F-1 F-1A E (Mooney) G 415-D A-2 A2-A M10 415-C 415-CD	A-767 AZEA A-787 A-787 A-787 A-787 A-787 A-787 A-787 A-718 A-718	CAR 3 CAR 3 CAR 3 CAR 3 CAR 3 CAR 3 CAR 3 CAR 3 CAR 3 CAR 3 CAR 4a	"	"	11012881 11072091	1/28/88 7/20/89	10/13/89	
57.	Verge Air- craft Corp.	2150Series	4A19	CAR 3	"	"	"	"	"	
58.	Waco Air- craft	A Series B8C Series D Series E Series G Series I, J, K Series O, P, Q Series R&S Series U, Y, Z Series	ATC26, 644 677 598 714 ATC41 ATC123 ATC168 ATC538 ATC639 ATC597 ATC42 563 ATC30 ATC 13 2-363 2-361 ATC 313 ATC468 ATC464 ATC491 ATC453 ATC502 ATC466 ATC311 ATC543 ATC512 ATC586 ATC627	ATC26 644 677 598 714 ATC41 ATC123 ATC168 ATC538 ATC639 ATC597 ATC42 563 ATC30 ATC 13 2-363 2-361 ATC 313 ATC468 ATC464 ATC491 ATC453 ATC502 ATC466 ATC311 ATC543 ATC512 ATC586 ATC627	"	"	"	"	10/13/89 5/11/92	
59.	Weatherly Aviation	201Series 620Series	A10ME A26ME	FAR 21.25 (a) FAR 21.25 (a)	"	"	"	"	"	